

# Physics goals and status of ICAL@INO

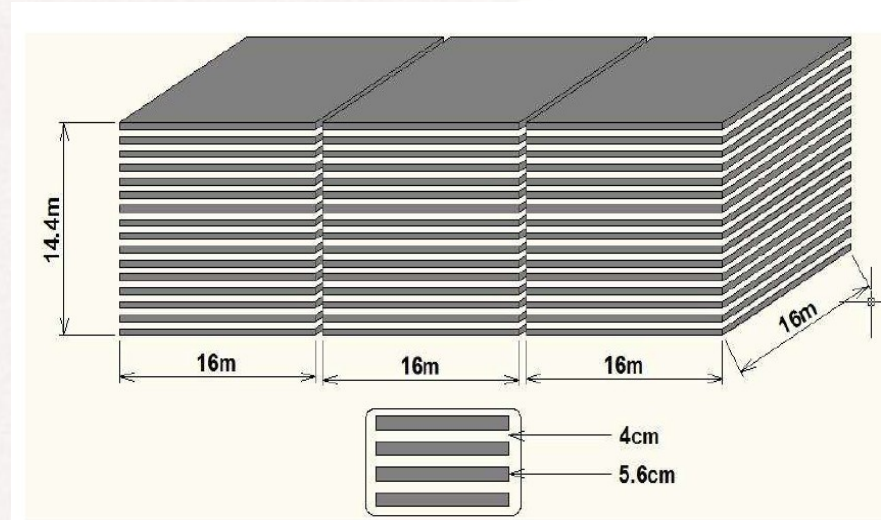

*Amol Dighe*

*TIFR, Mumbai*

*(On behalf of the INO Collaboration)*

*<http://www.ino.tifr.res.in/ino/>*

**INO**

*DAE-BRNS HEP Symposium  
Santiniketan, Jan 2013*





# INO Collaboration

*Ahmadabad: Physical Research Lab.*

*Aligarh: Aligarh Muslim University*

*Allahabad: HRJ*

*Bhubaneswar: IOP*

*Calicut : University of Calicut*

*Chandigarh: Panjab University*

*Chennai : IIT, Madras IMSc*

*Delhi : University of Delhi*

*Guwahati : IIT, Guwahati*

*Hawaii (USA) : University of Hawaii*

*Indore: IIT, Indore*

*Jammu : University of Jammu*

*Kalpakkam : IGCAR*

*Kolkata : Ramakrishna Mission Vivekananda University,  
SINP, VECC , University of Calcutta*

*Lucknow : Lucknow University*

*Madurai : American College*

*Mumbai : BARC*

*Mumbai : IIT, Bombay TIFR*

*Mysore : University of Mysore*

*Sambalpur : Sambalpur University;*

*Srinagar : University of Kashmir*

*Varanasi : Banaras Hindu University*





# *INO: physics goals*

# Neutrino oscillations: current status

*sol*

*atm*

Hot news 2012

*sol*

*atm*

Parameter	Best Fit Value	$3\sigma$ Range
$\sin^2 \theta_{12}$	0.307	0.259-0.359
$\sin^2 \theta_{23}$	0.386	0.331-0.637 (NH)
	0.392	0.335-0.663 (IH)
$\sin^2 \theta_{13}$	0.0241	0.0169-0.0313 (NH)
	0.0244	0.0171-0.0315 (IH)
$\Delta m_{21}^2$ (eV <sup>2</sup> )	$7.54 \times 10^{-5}$	$6.99-8.18 \times 10^{-5}$
$ \Delta m_{31}^2 + \Delta m_{32}^2 /2$	$2.43 \times 10^{-3}$	$2.19-2.62 \times 10^{-3}$ (NH)
(eV <sup>2</sup> )	$2.42 \times 10^{-3}$	$2.17-2.61 \times 10^{-3}$ (IH)



# Neutrino properties: key parameters

- *Precise values of neutrino parameters:*

$$|\Delta m^2(\text{atm})|, \Delta m^2(\text{sol}), \theta_{12}, \theta_{23}, \theta_{13}$$

- *The sign of  $\Delta m^2(\text{atm})$ , i.e. Neutrino mass hierarchy (MH)*
- *CP violation in the lepton sector*
- *Absolute masses of neutrinos*
- *Non-standard neutrino interactions*
- *....*

*An experiment should choose its own tools !*

# *INO: chosen materials and tools*

- *Atmospheric neutrinos provide a wider range for  $E$  and  $L$  than any artificial neutrino source*
- *An ability to discriminate between neutrinos and antineutrinos enables efficient determination of neutrino mass ordering*
- *Magnetized iron calorimeter (ICAL): excellent muon energy measurement, muon direction reconstruction and charge identification*
- *Hadron shower reconstruction allows access to neutrino energy and high-energy cosmic rays*



# *INO: the physics goals*

- *Accurate determination of the atmospheric parameters  
( $\theta_{23}$  octant, deviation of  $\theta_{23}$  from maximality)*
- *Determination of neutrino mass hierarchy  
(large  $\theta_{13}$  is good news !)*
- *Determination of CP violation in the lepton sector  
(with a future long baseline experiment with a neutrino factory)*
- *Non-standard interactions, CPT violation, long range forces, ultrahigh-energy muon fluxes, ...*

# *INO: the location*



# *The site: Bodi West Hills*

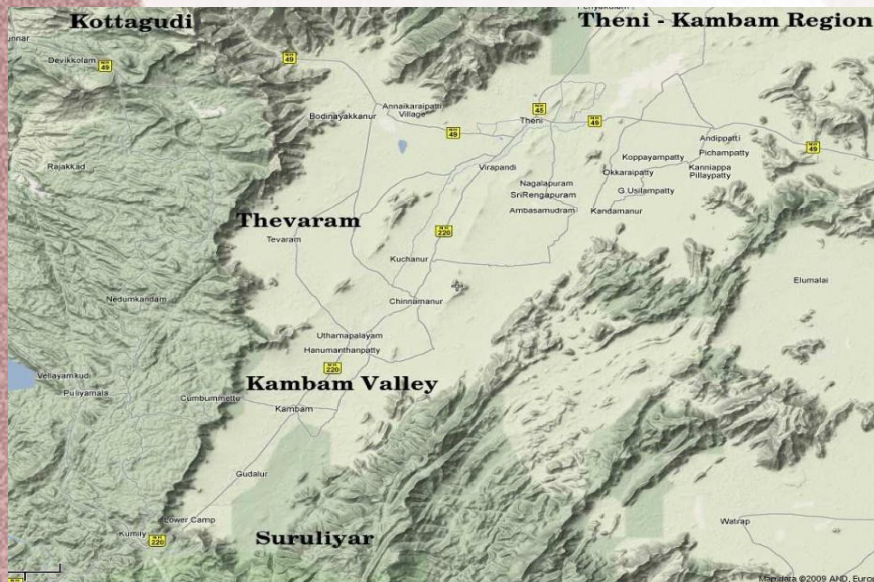
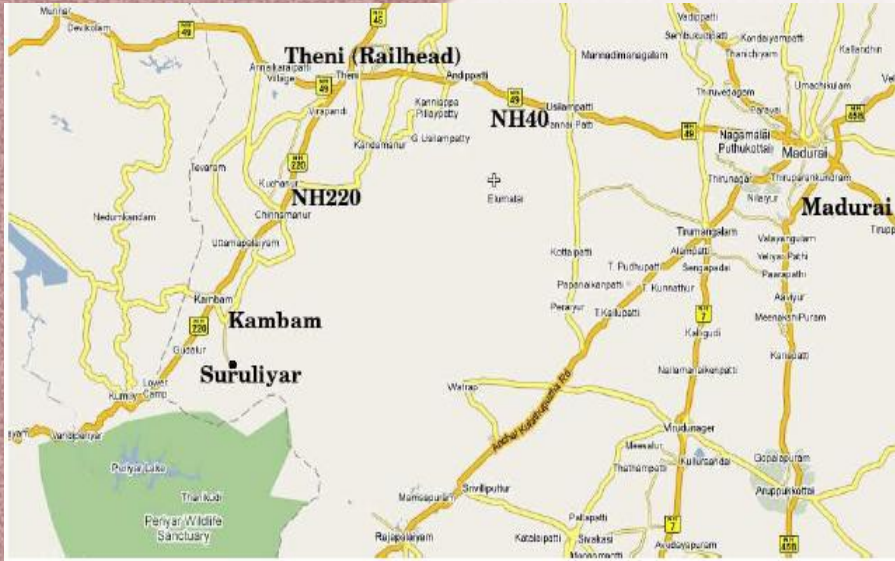

- *(9°58' N, 77°16' E)*
- *Pottipuram village*
- *Theni district*
- *Tamil Nadu state*
- *120 km from Madurai*



# The caverns

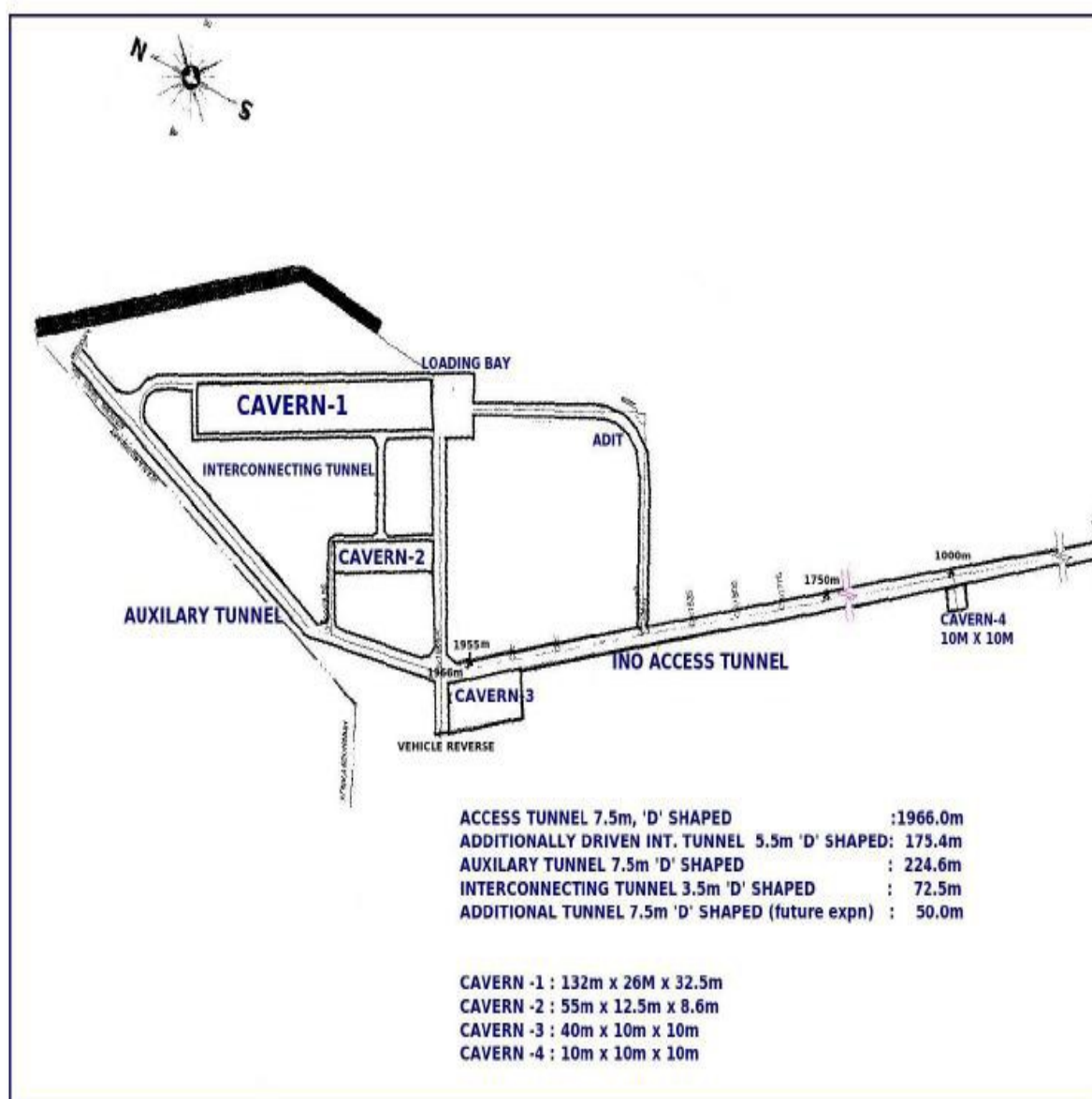

- Accessible through a 2km tunnel
- Cavern 1 will host 50kt ICAL (space for 100 kt)
- Other caverns available for multiple experiments (NDBD, dark matter, ...)
- Shall not talk about Tintin and DINO



# Geography of the site

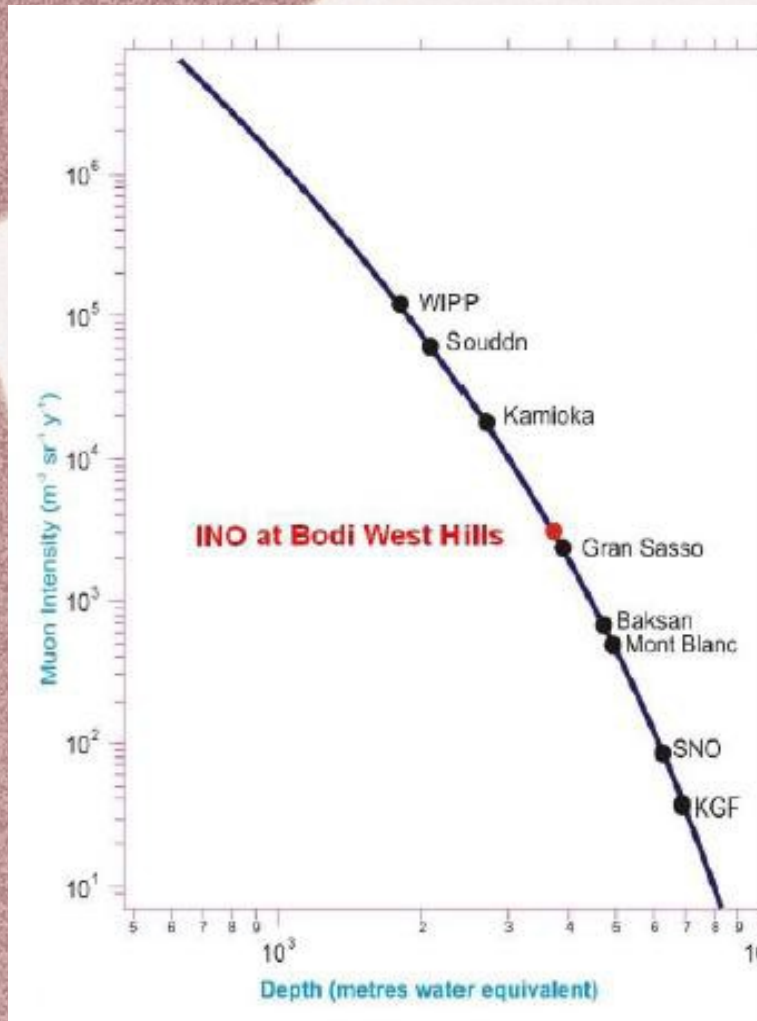

- *Cavern set in Charnockite rock under the 1589 m peak*
- *Vertical cover: 1289 m, all-round cover ~1000m*
- *Warm, low-rainfall area, low humidity throughout the year, unusual wind speed in some seasons*

# *Organization at the site*

- *Flat terrain with good access to major roads*
- *All major components to be located underground , Small surface lab on the outside (Pottipuram)*
- *Tunnel and cavern under forest on the surface, but the portal outside the reserve forest boundary*
- *Surface facilities not on the forest land, so no forest clearing required.*



# *Updates on the site front*

- *INO project approved by DAE and DST*
- *Environmental and Forest Clearance for the site obtained. 26 hectares of land provided free by Tamil Nadu state government*
- *Site preparation works are being tendered.*
- *Funds have already been transferred to the Tamil Nadu government from the INO budget, for construction of approach roads and water connection to the INO site*
- *Construction of an INO Centre: National Centre for High Energy Physics (NCHEP) planned at Madurai, land has been acquired.*
- *The fencing of both, Pottipuram and Madurai lands, will start soon.*

# *INO-ICAL: The detector*



# *Magnetized Iron calorimeter (ICAL)*

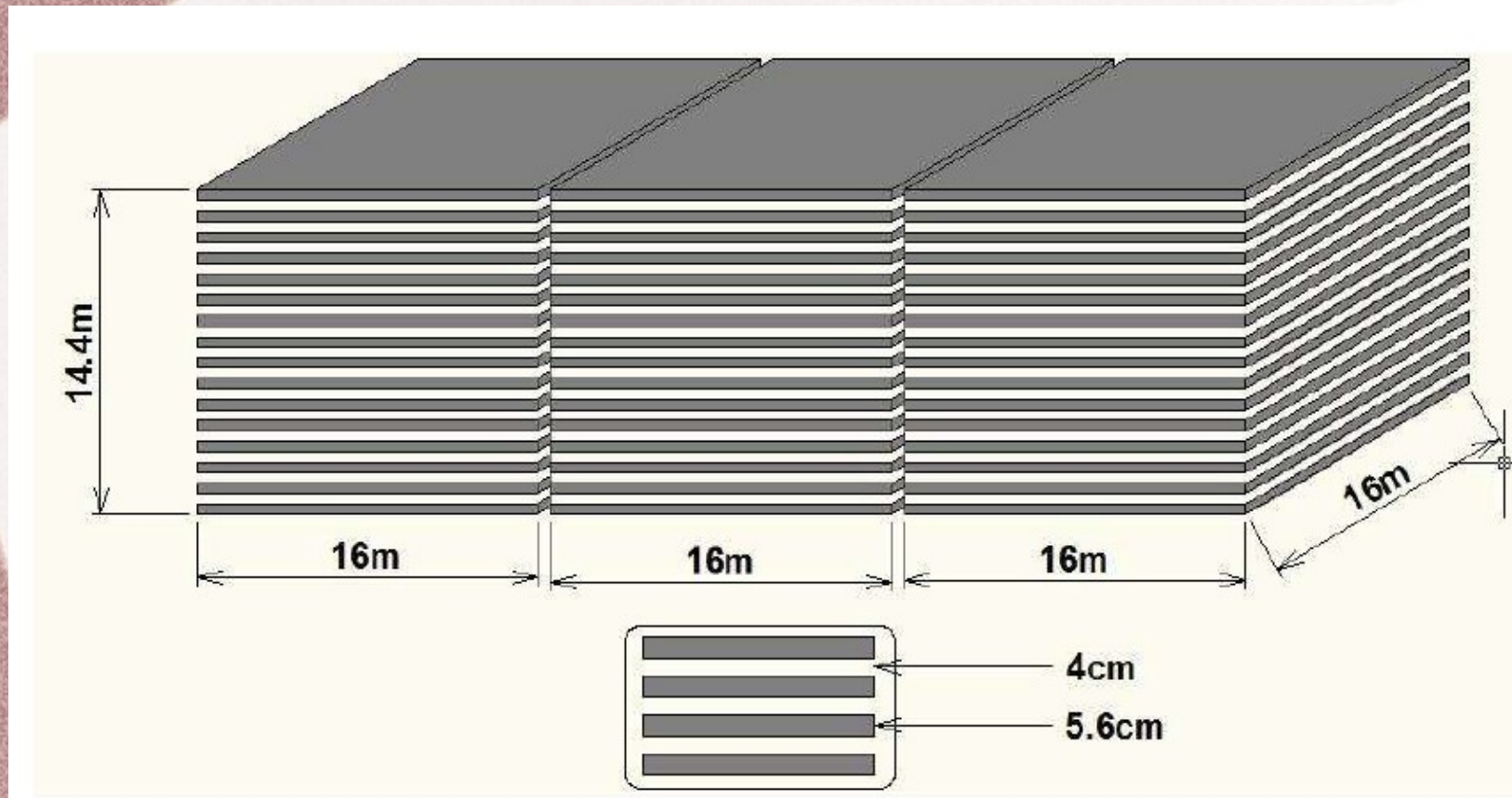

- *Iron plates separated by resistive plate chambers (RPCs): 150 layers*

# *Salient features of the detector*

- *Magnetized iron as target mass and glass RPCs as the active detector*
- *Modularity and ease of construction*
- *Good energy measurement through tracking of muons bending in the magnetic field*
- *Directionality through tracking and timing ( $\sim 1\text{ns}$  resolution)*
- *Charge identification through bending of muons*
- *Complementarity to existing and future detectors*



# *Detector factsheet*

<b>No. of modules</b>	<b>3</b>
<b>Module dimensions</b>	<b>16m × 16m × 14.5m</b>
<b>Detector dimensions</b>	<b>48.4m × 16m × 14.5m</b>
<b>No. of layers</b>	<b>150</b>
<b>Iron plate thickness</b>	<b>56mm</b>
<b>Gap for RPC trays</b>	<b>40mm</b>
<b>Magnetic field</b>	<b>1.3 Tesla</b>
<b>RPC dimensions</b>	<b>1,950mm × 1,840mm × 24mm</b>
<b>Readout strip pitch</b>	<b>3 0mm</b>
<b>No. of RPCs/Road/Layer</b>	<b>8</b>
<b>No. of Roads/Layer/Module</b>	<b>8</b>
<b>No. of RPC units/Layer</b>	<b>192</b>
<b>No. of RPC units</b>	<b>28,800 (97,505m<sup>2</sup>)</b>
<b>No. of readout strips</b>	<b>3,686,400</b>

# Construction of the ICAL

Fig. 7.6 Bottom Layer with Coil Lower Parts on Foundation

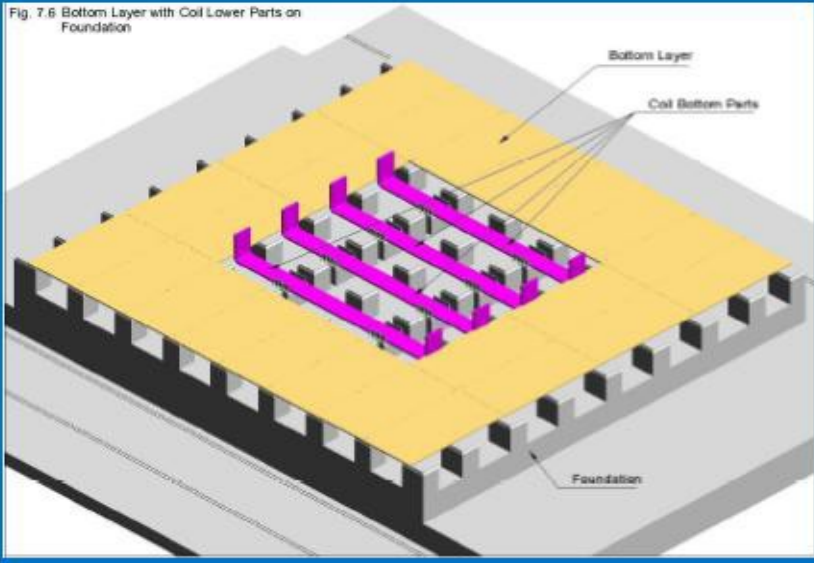

Fig. 7.11.b Building up the Stack with Plates, Spacers, Bearing Strips and Coil Parts

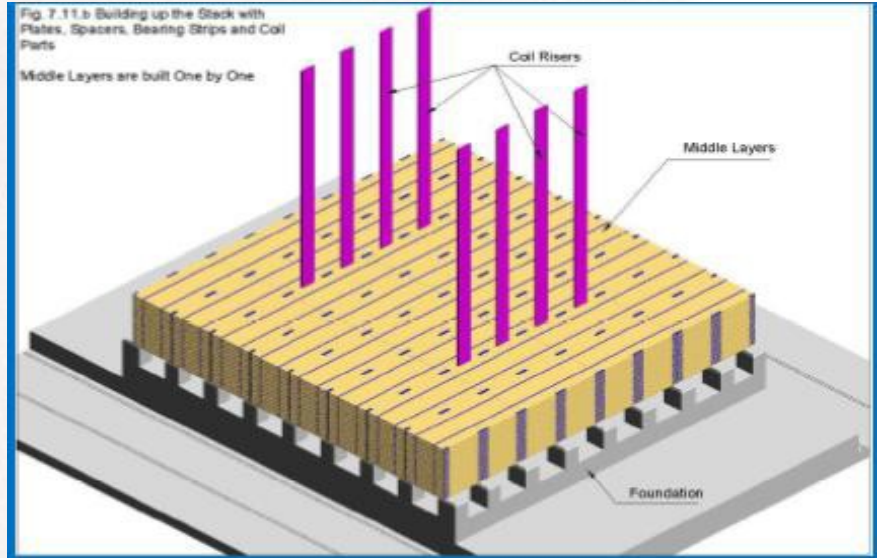
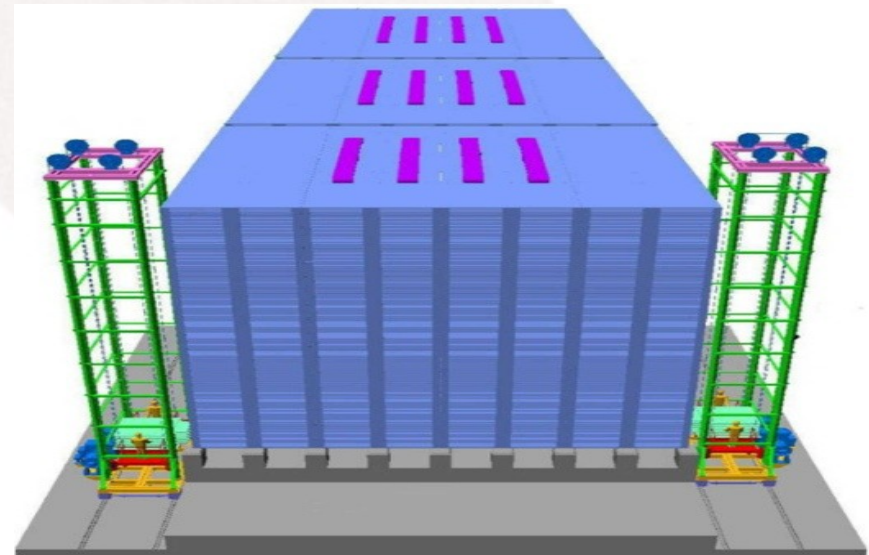
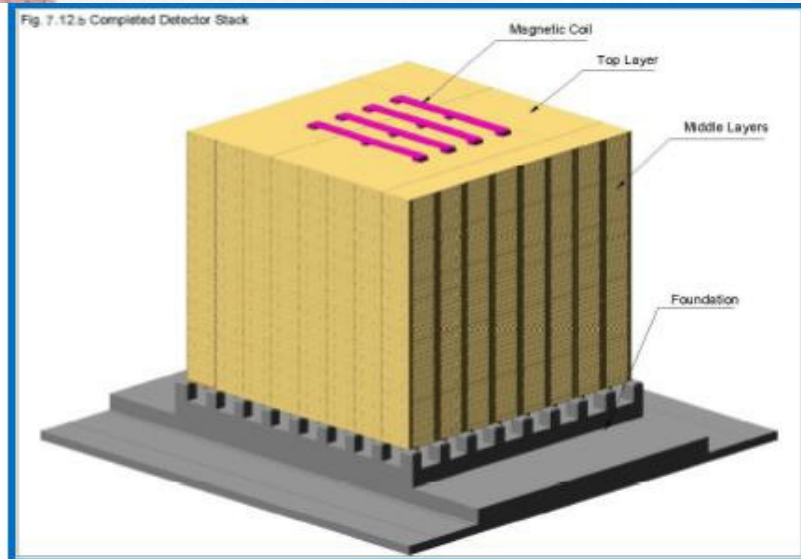

Fig. 7.12.b Completed Detector Stack





# Magnetic field map

$y=16\text{m}$

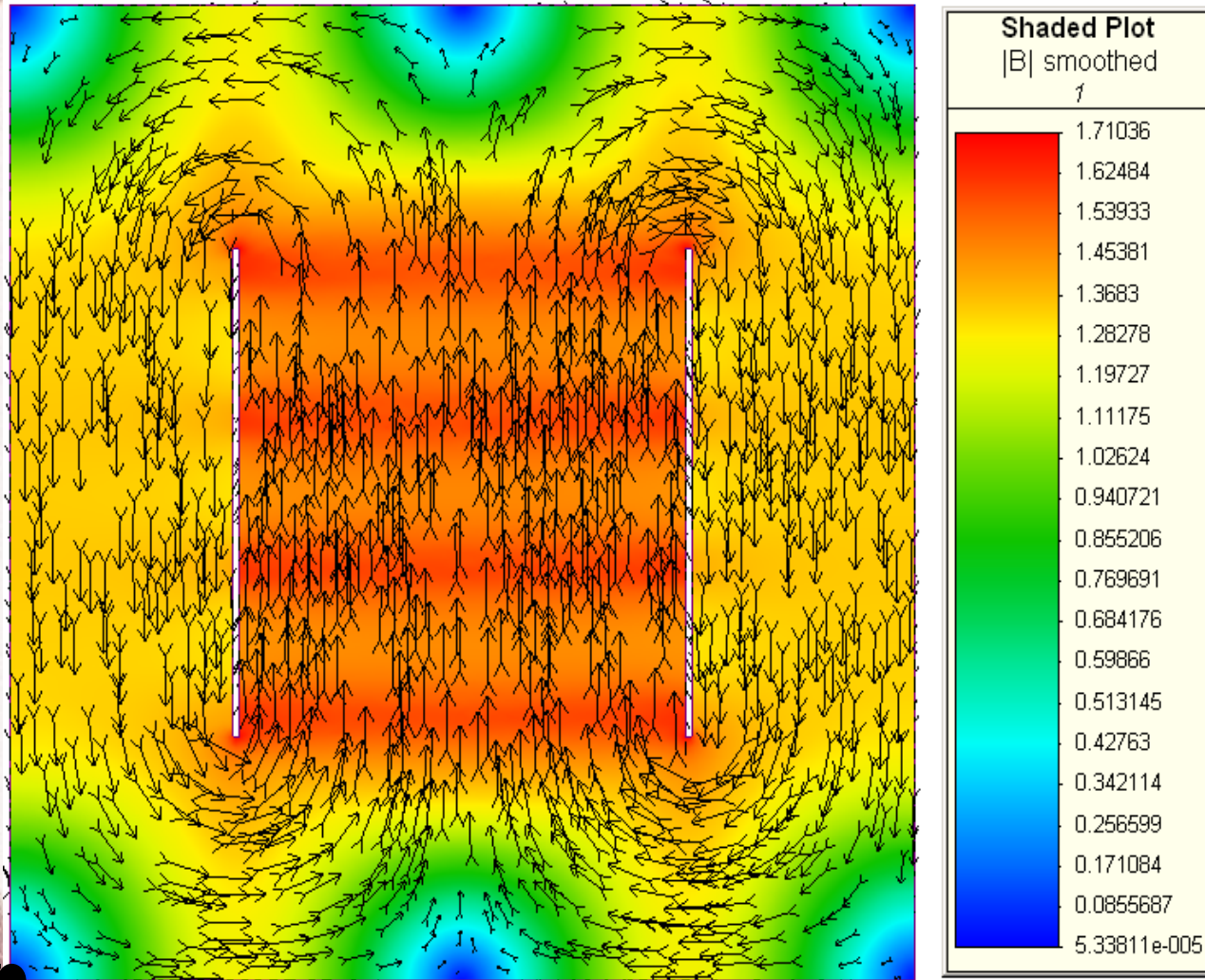

$(0,0)$

$X = 16\text{m}$

*Talk by  
Shiba Prasad  
Behera*



# *RPC and its DAQ*

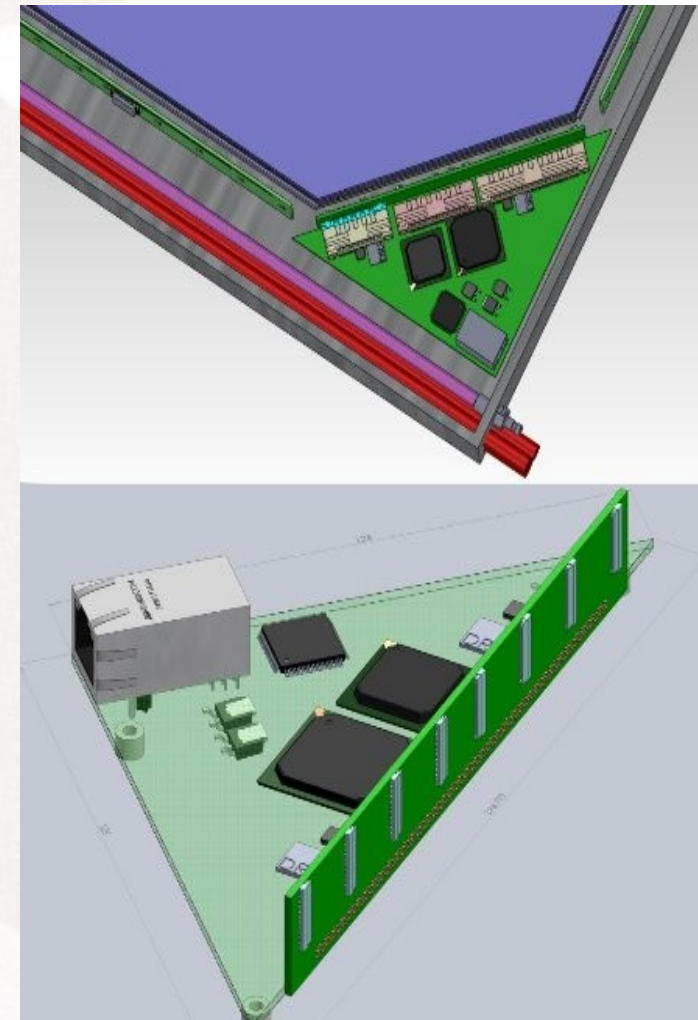
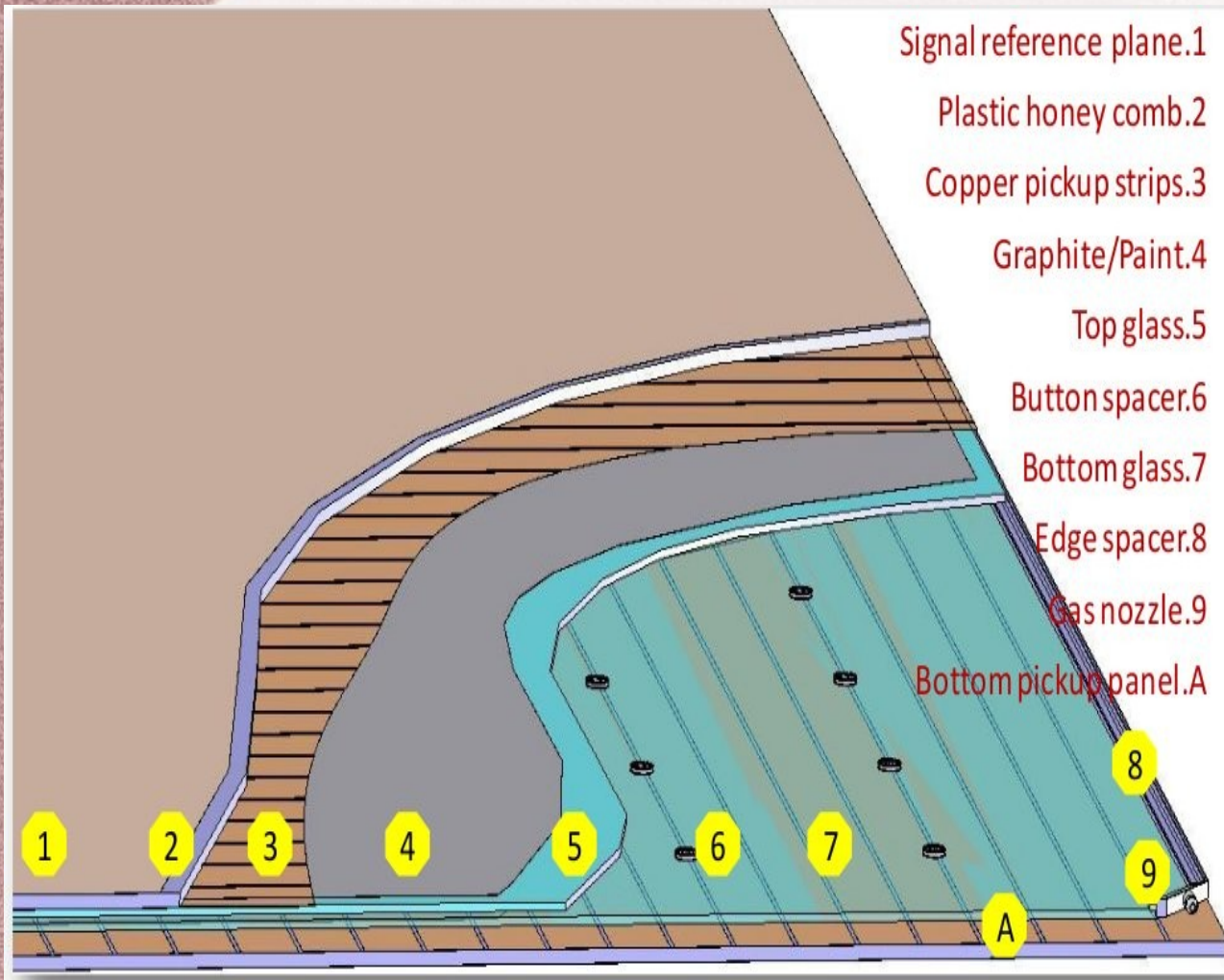



# ICAL Front End Electronics chip developed at BARC Electronics Division

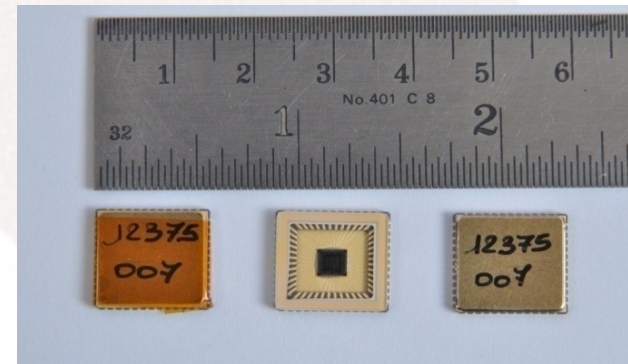
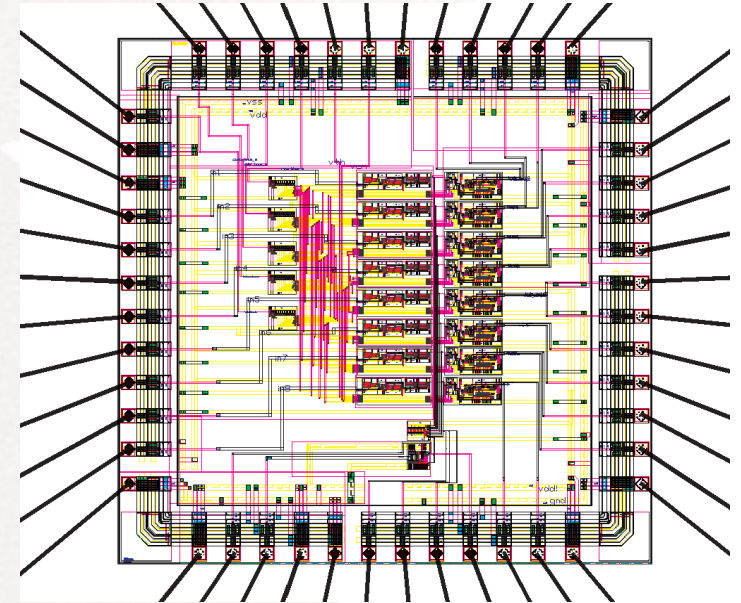
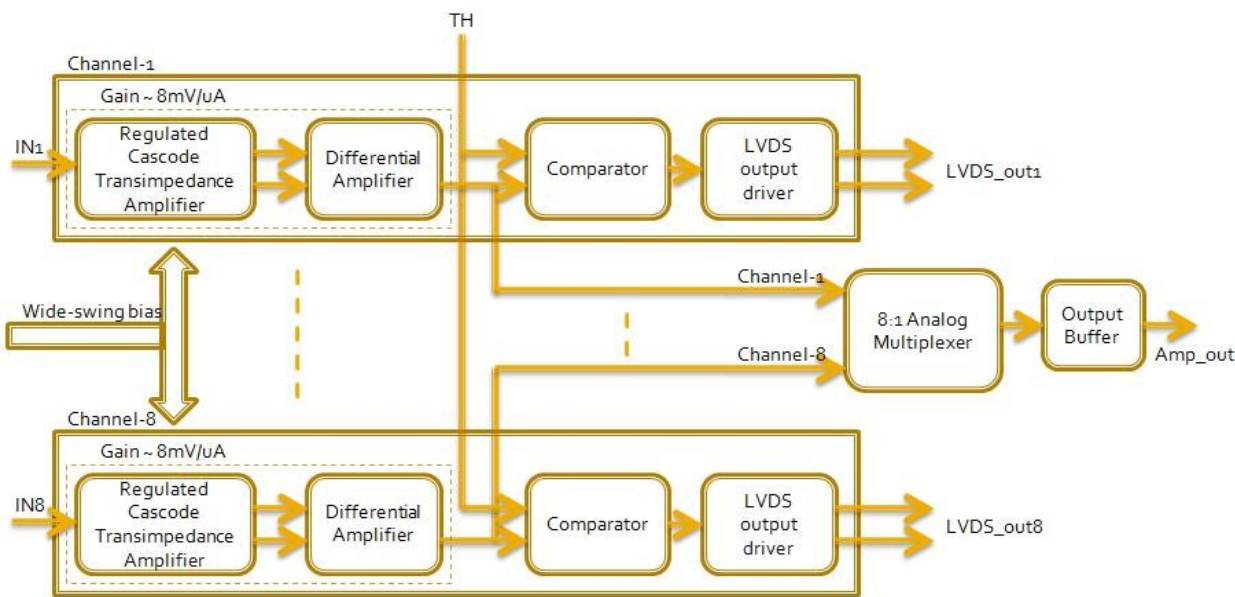

(Talk by B. Satyanarayana)



# *1 m x 1 m RPC stack at TIFR: Cosmic ray measurements*



*(Talk by Sumanta Pal)*

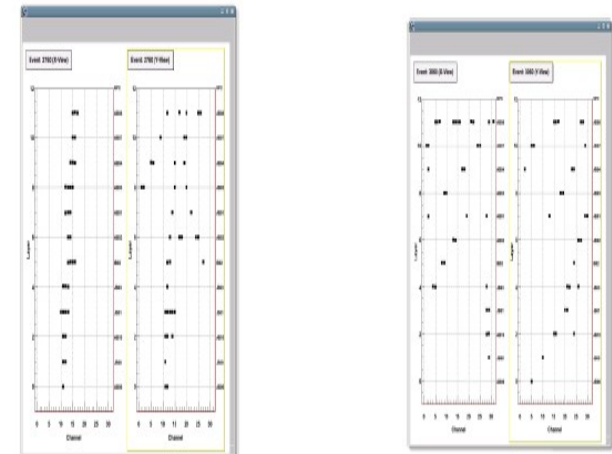
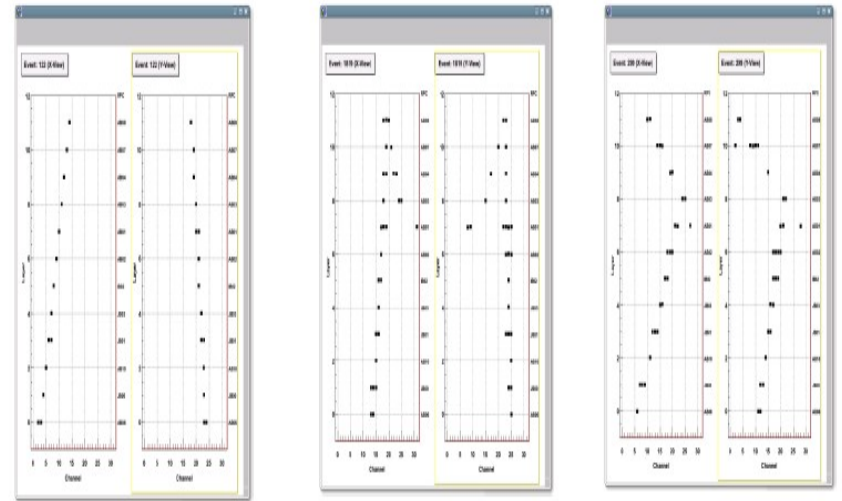



# *2m x 2m glass RPC test stand*

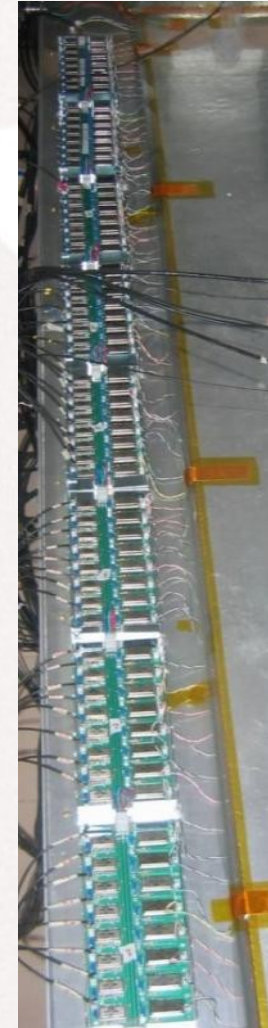



# Bakelite RPC R&D

- *SINP and VECC groups in Kolkata developing bakelite RPCs in streamer mode*
- *Inner surface of bakelite coated with PDMS (silicone) to make the surface smooth*
- *Efficiency plateau over 96% obtained with reduced noise rate and long term stability*
- *INO-ICAL being modular, can use both, glass and/or bakelite RPCs*

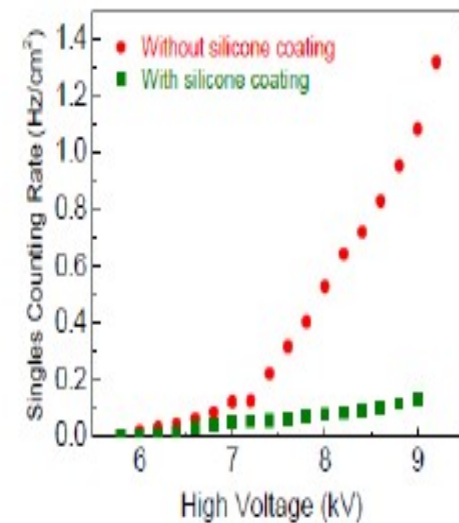
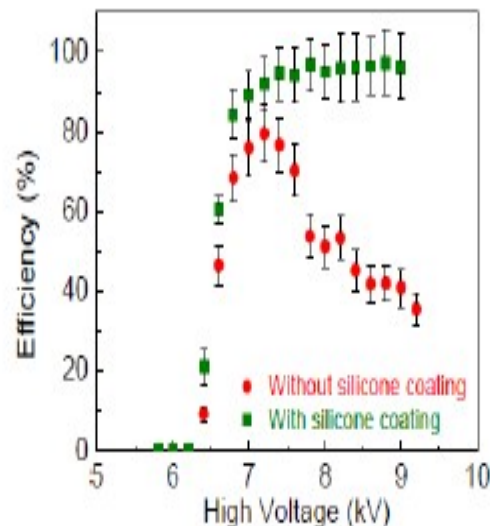
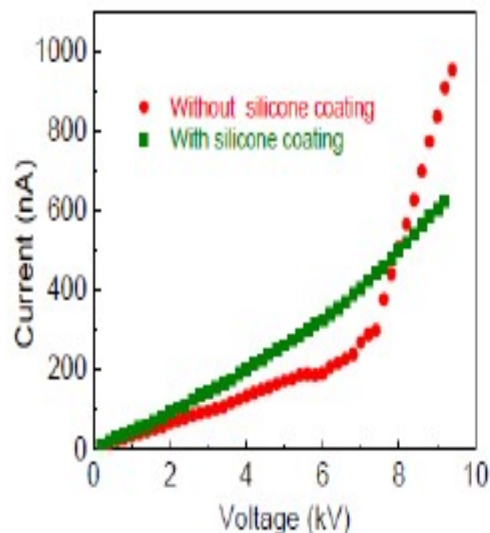



# *Detector prototype (40 ton) in Kolkata*

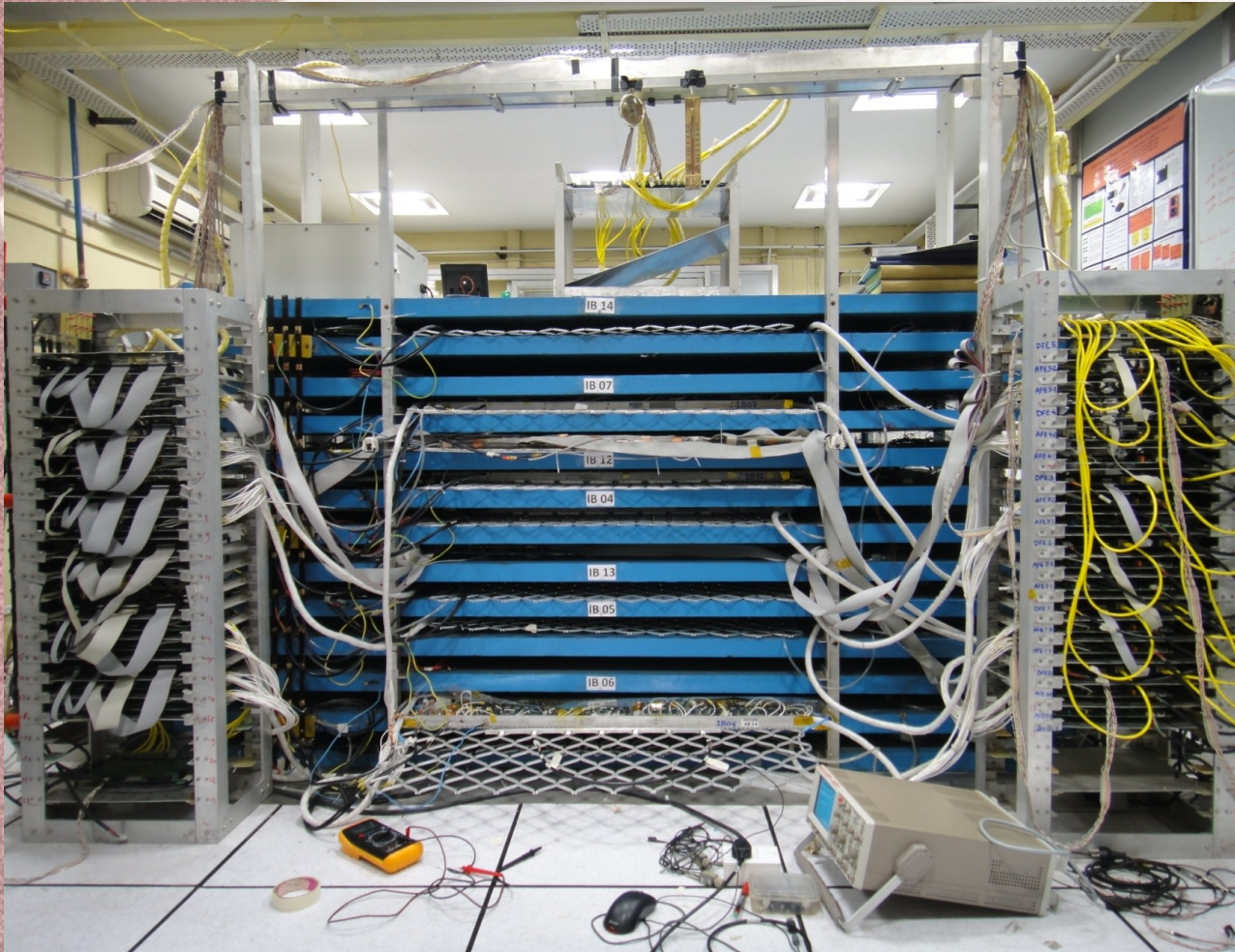

- *Both, glass and bakelite RPCs tested in this magnetized ICAL prototype*



# *Status of detector development*

- *RPC development for ICAL:*

- *R&D almost complete*
- *Full size RPCs (2m X 2m) are being fabricated not just in the INO labs but also by the industry*
- *Methods, machinery and production optimization for large scale production of RPCs are being developed with the help of an industry*

- *Electronics for ICAL*

- *Design and prototyping of electronics, trigger and data acquisition systems progressing well.*
- *First batch of ASIC front end designed by the INO electronics team & fabricated by Euro Practice IC Services being tested in the RPC lab*
- *TDC ASIC developed at IIT Madras*

- *Magnet for ICAL*

- *Prototype magnet running at VECC, Kolkata*

*8m x 8m x 20 layer engineering module (800 ton) being planned*



# *INO: Simulations*

# Overview of simulation framework

## Simulation Framework

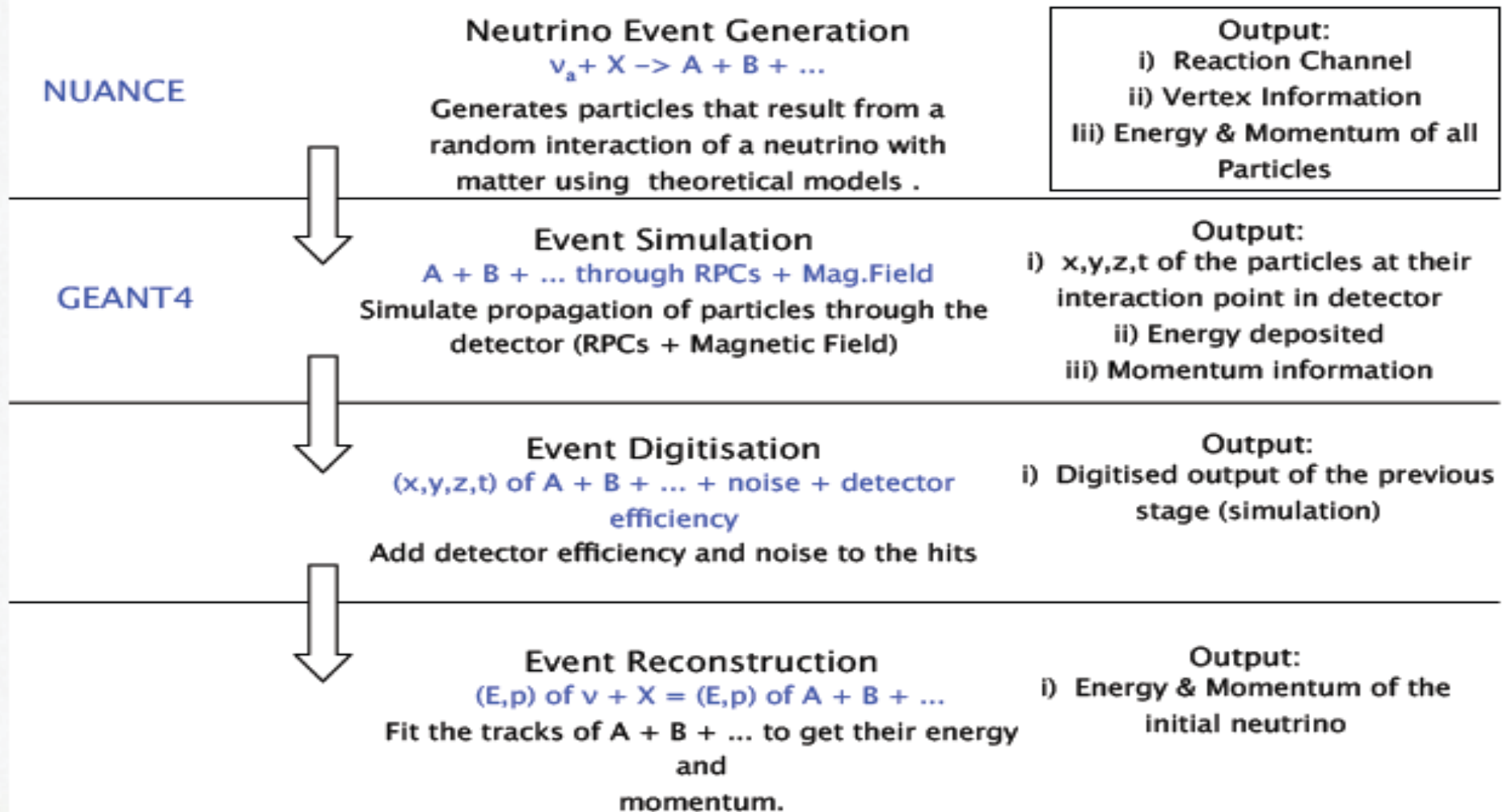



# *The status of INO simulations*

- *MC code for generating atmospheric neutrino events at the INO site getting ready. Current results use fluxes at SK.*
- *Complete detector geometry implemented in GEANT4, including the inhomogeneous magnetic field*
- *Muon track reconstruction: good understanding of energy and direction resolution, but improvements still possible (talk by Meghna)*
- *Hadron energy resolutions available, but not used in the physics analysis results yet. Optimization of iron plate thickness in progress (talk by Lakshmi S Mohan)*
- *Neutrino energy reconstruction using muon and hadron momenta possible (poster by Moon Moon Devi)*

# Muon efficiencies and resolutions

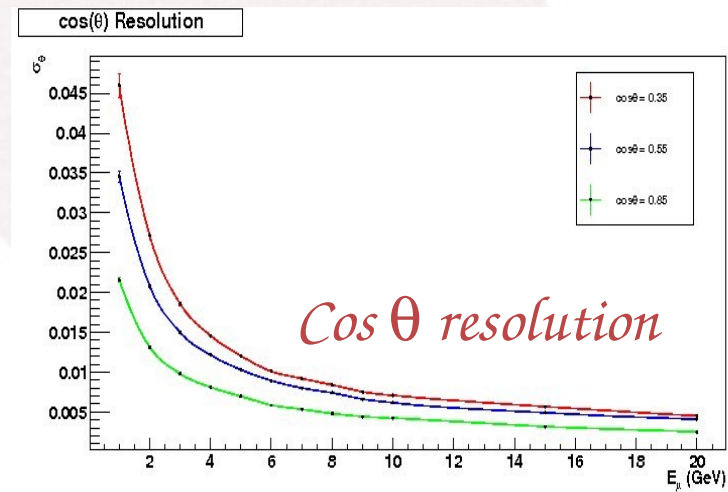
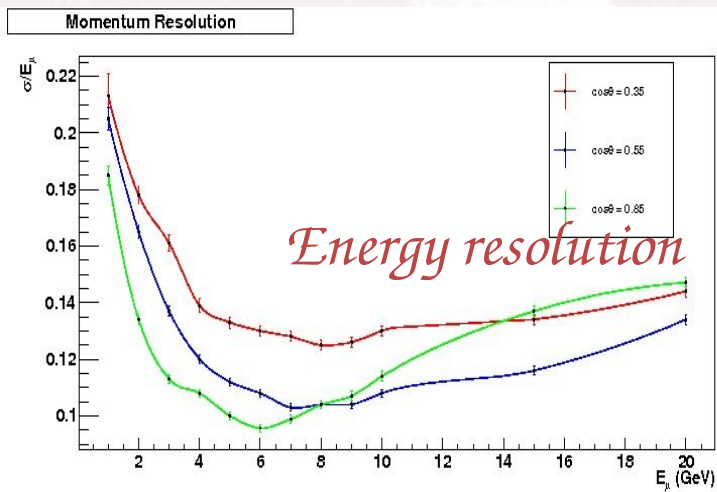
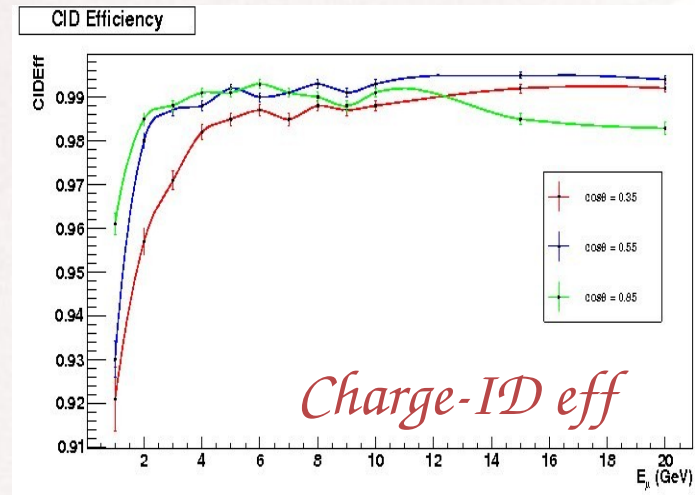
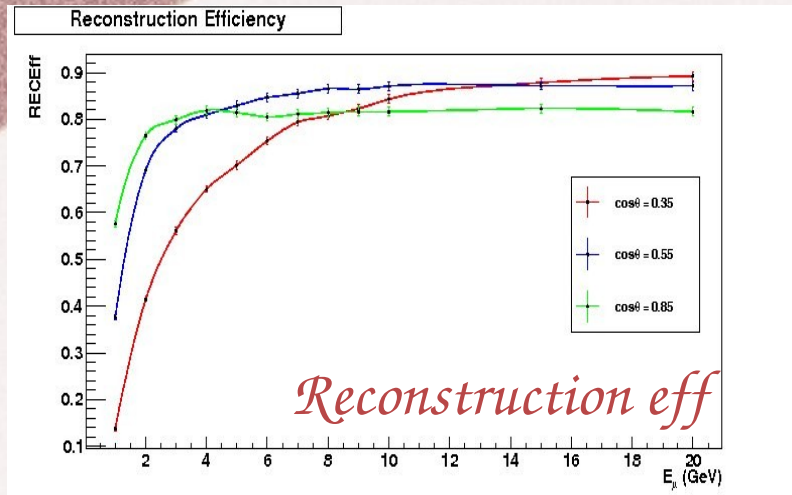



# Hadron energy resolutions

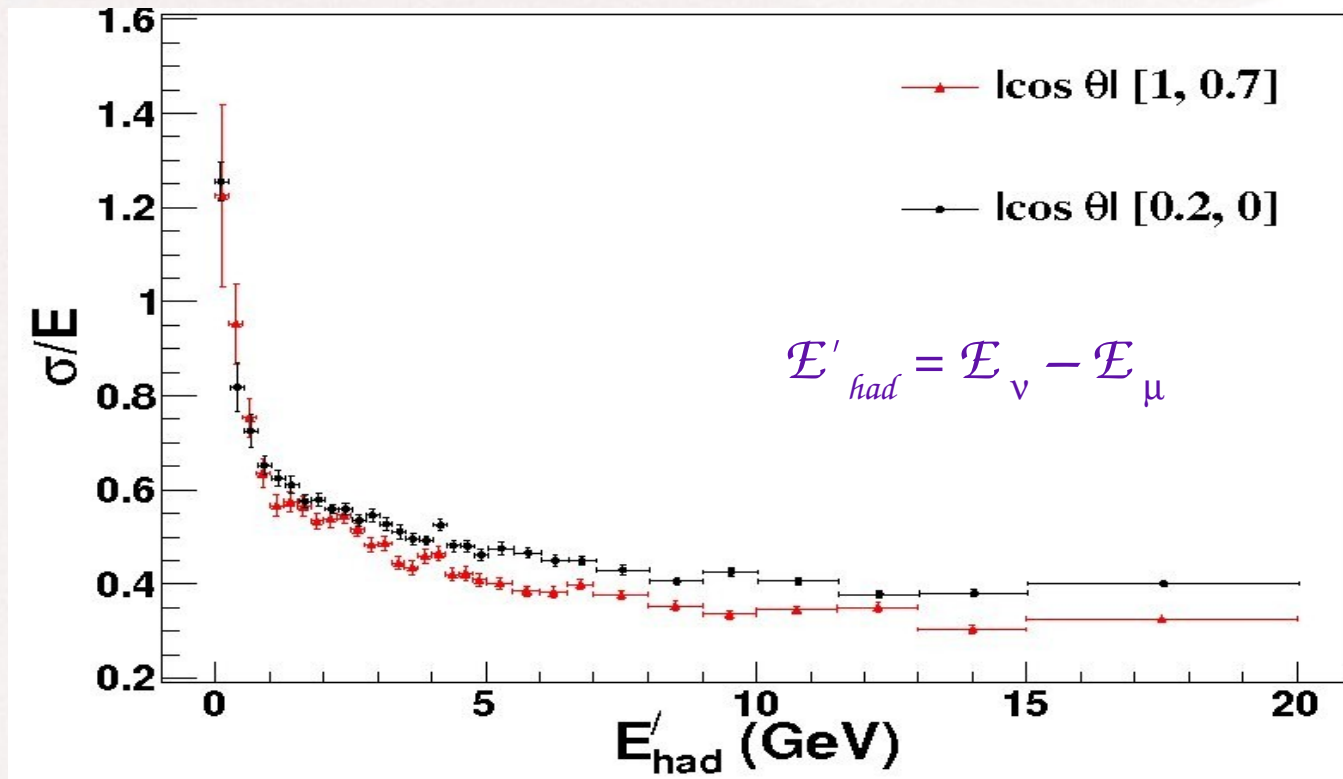

*(Talk by Lakshmi S Mohan and poster by Daljeet Kaur)*

- *These can further be used for neutrino energy resolution*

# Mass hierarchy with INO-ICAL

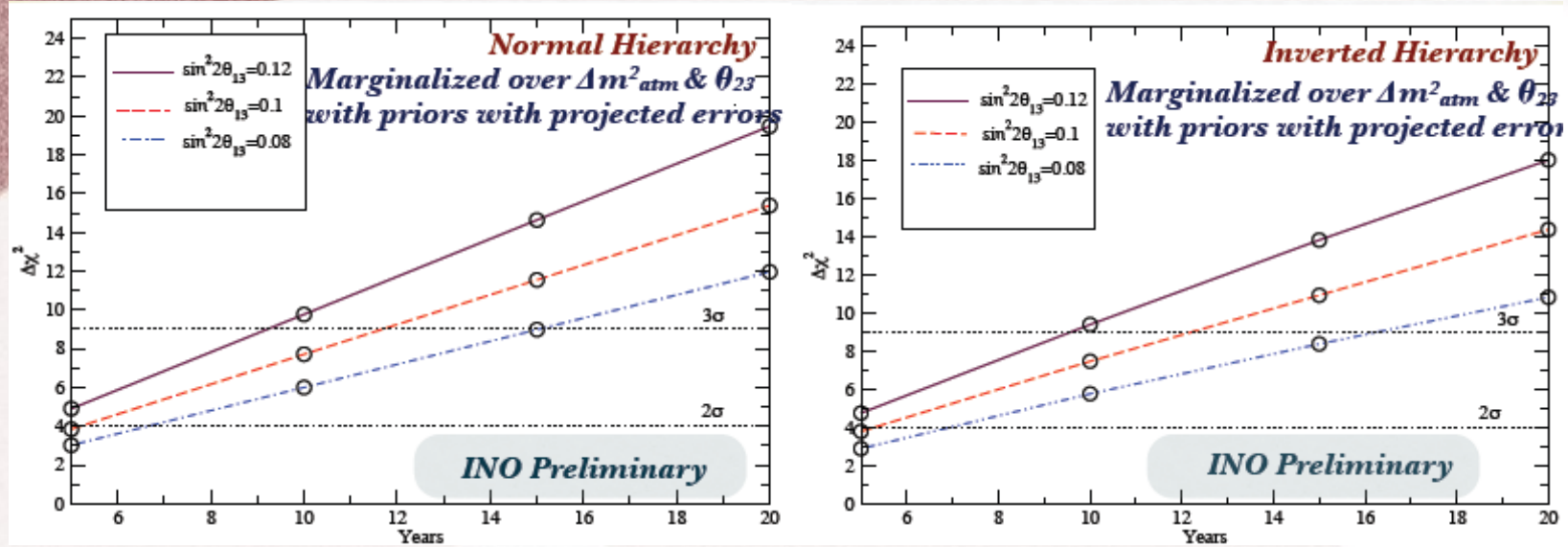

- Events generated using *NUANCE* and *ICAL* resolutions in  $\mathcal{E}$  and  $\cos(\theta_{zenith})$
- Sensitivity independent of  $CP$  phase, as opposed to at the long baseline expts
- For  $\sin^2 \theta_{23} = 0.5$ ,  $\sin^2 (2\theta_{13}) = 0.1$  :

In 5 years, 2 sigma sensitivity to  $MH$ , in 10 years, 2.7 sigma

A. Ghosh, T. Thakore, S. Choubey, hep-ph/1212.1305, Talk by Anushree Ghosh



# Atmospheric parameters with INO-ICAL

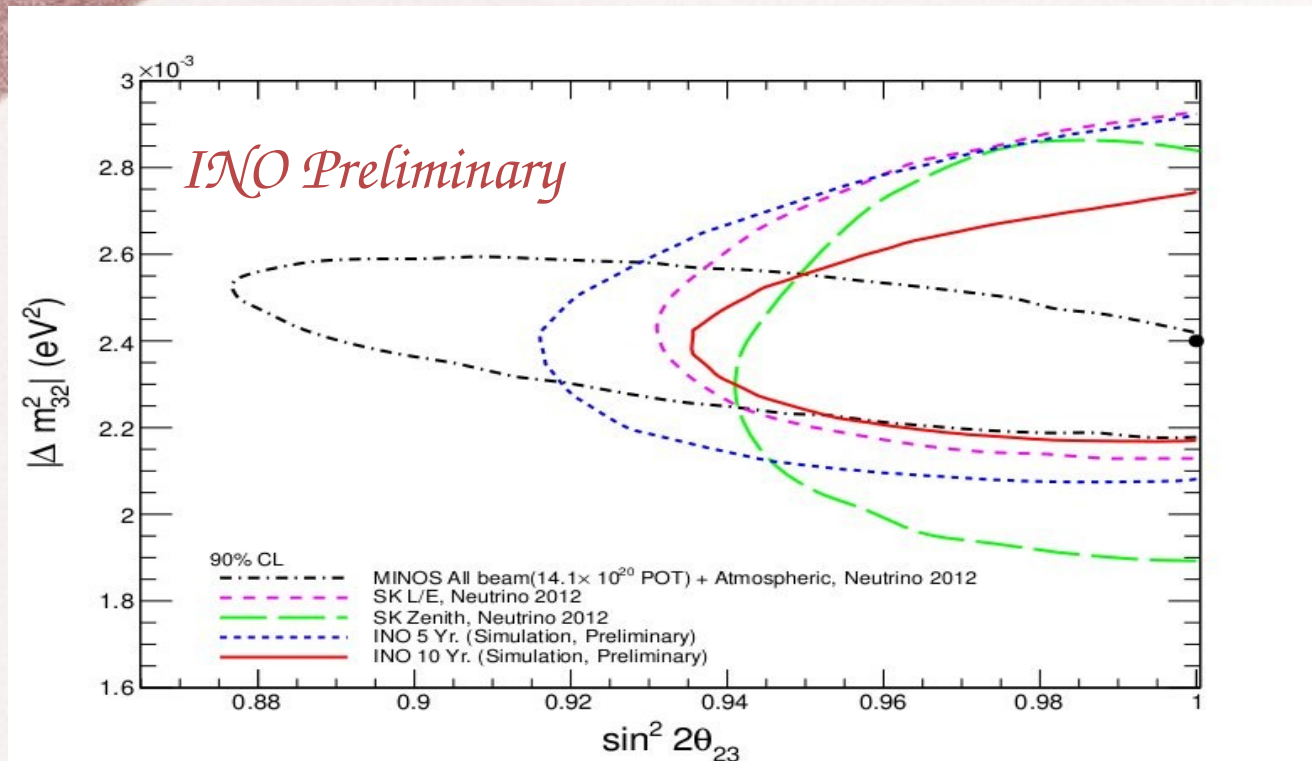

- Priors used on projected reach of  $|\Delta m^2_{32}|, \theta_{23}, \theta_{13}$
- Precision complementary to LBL experiments:  
better for  $\theta_{23}$ , but worse for  $|\Delta m^2_{32}|$
- Performance comparable to SK with a similar exposure

T. Thakore, A. Ghosh, S. Choubey

# $\theta_{23}$ octant and deviation from maximality

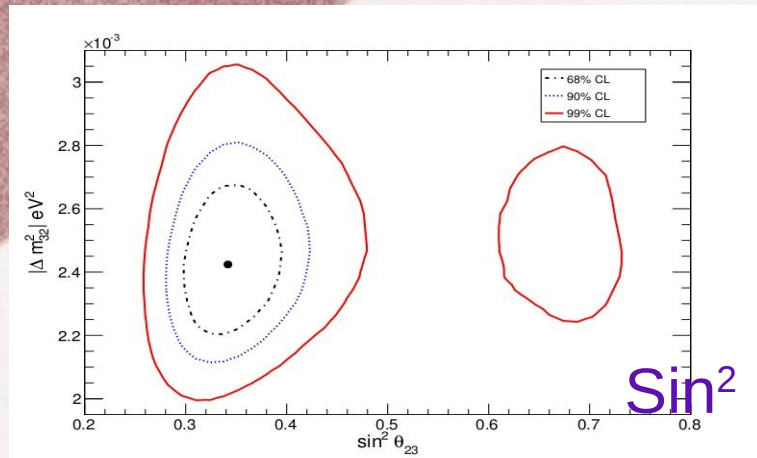

$$\sin^2 2\theta_{23} = 0.9$$

First octant

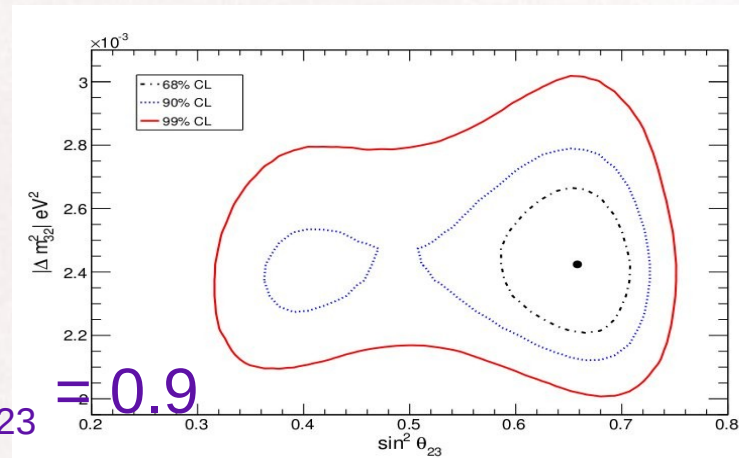

Second octant

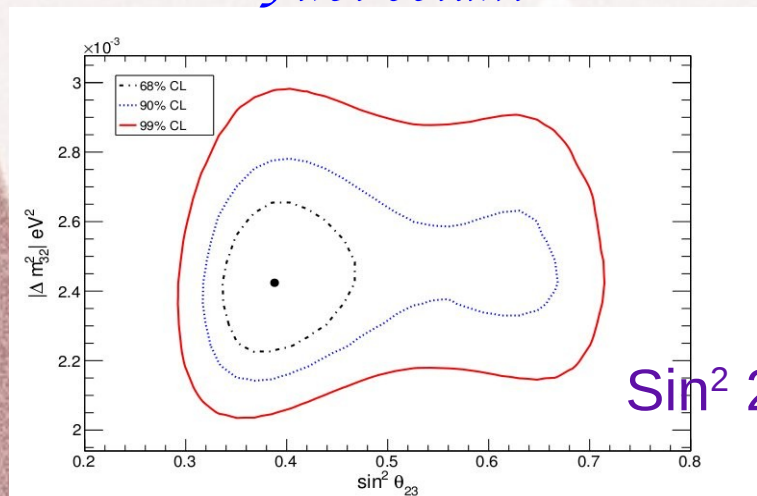

$$\sin^2 2\theta_{23} = 0.95$$

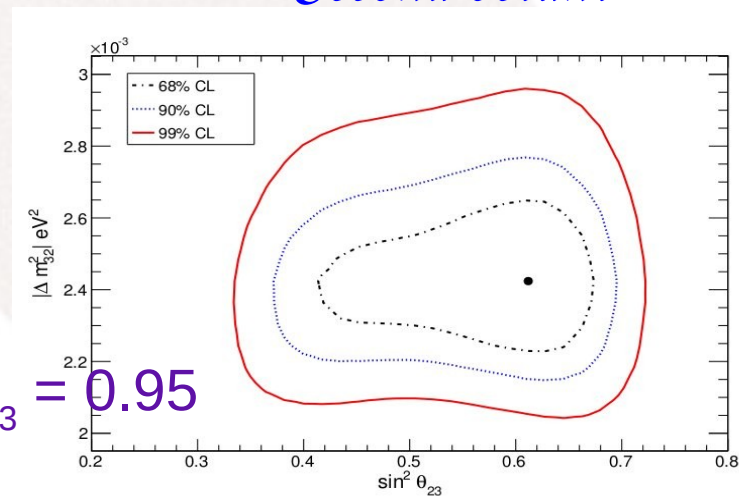

10 years of 50 kt ICAL



# *More analyses in progress*

- *Improvement of Kalman-filter algorithm for muon track reconstruction (talk by Kollahal Bhattacharya)*
- *Sensitivity for CPT violating parameters (talk by Animesh Chatterjee)*
- *Analysis of upward-going muons produced from neutrino interactions in the surrounding rock (talk by Kanishka Rawat)*
- *Study of background from  $\tau$  events (talk by Sumanta Pal)*
- *...*

# *INO: Timeline*



# INO-ICAL timeline

SN	Description of work	2011-12	2012-13	2013-14	2014-15	2015-16	2016-17
<b>Civil work at Pottipuram</b>							
1	Land acquisition and pre-project work	←→					
2	Architectural and Engineering consultancy	←→					
3	Tendering and award of contracts		←→				
4	Mining of access portal		←→				
5	Excavation of tunnel		←→	←→			
6	Excavation of caverns				←→	←→	
7	Installation of services, cranes, lifts etc.					←→	
8	Civil work for magnet support bed					←→	
9	Surface facilities		←→	←→	←→		
<b>Magnet</b>							
10	Procurement of steel plates			←→	←→		
11	Machining job for steel plates				←→	←→	
12	Transportation of machined plates at site					←→	
13	Procurement of copper coils				←→	←→	
14	Assembly/erection of magnet (3 modules)						←→
<b>RPC</b>							
15	Finalization of all design details, tendering	←→					
16	Procurement of components		←→				
17	Fabrication and assembly of 30000 pcs		←→	←→	←→		
18	Transportation to site and tests				←→	←→	
19	Procurement of electronics, gas handling			←→	←→		
20	Installation and commissioning						←→

*(This is the original plan, currently we are about an year behind this schedule.)*

# *INO Graduate school and training*

- *INO Graduate Training Program from Aug 2008  
(affiliated to HBN(I))*
- *One year training in TIFR in both, experimental techniques and theory. After completion of coursework, attached to Ph.D. Guides in collaborating institutions*
- *Many short/long term visits to RPC labs (Mumbai and Kolkata) of students and faculty from universities in last several years.*



*Collaborators are welcome !*



*<http://www.ino.tifr.res.in/ino/>*



# *Backup slides*



# Construction of RPC

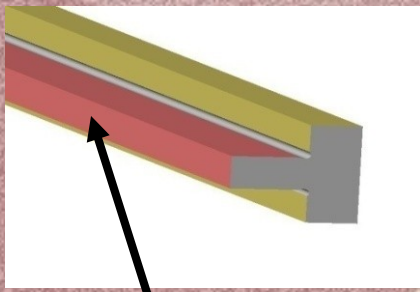

*Two 2 mm thick float Glass  
Separated by 2 mm spacer*

*2 mm thick spacer*

*Pickup strips*

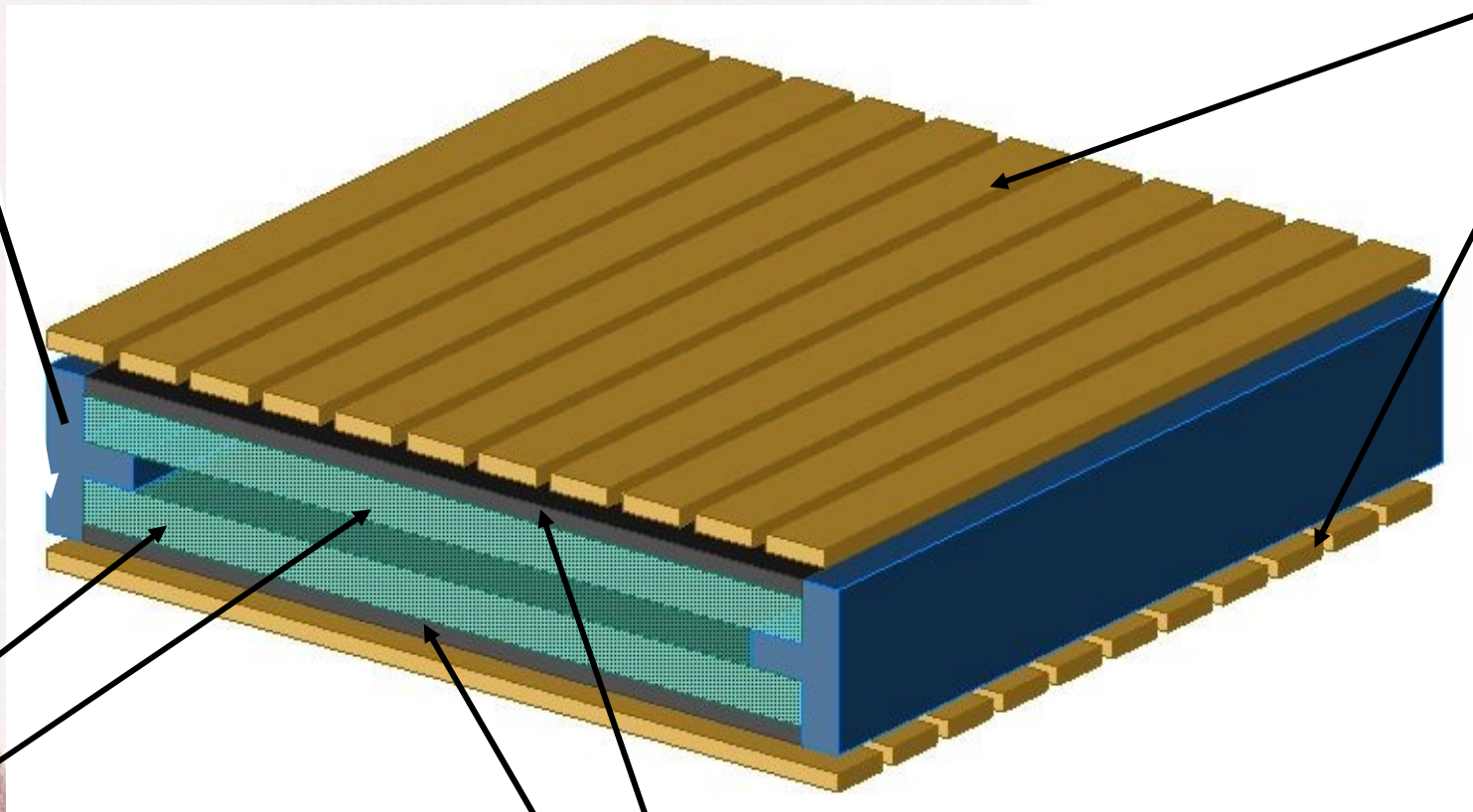

*Glass plates*

*Resistive coating on the outer surfaces of glass*



# Testing the RPCs



*RPC stack being used for cosmic ray measurements*

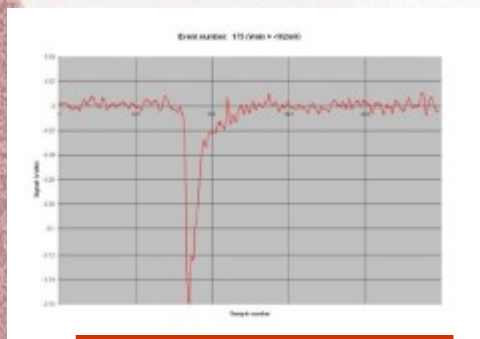

**Muon Pulse in RPC**

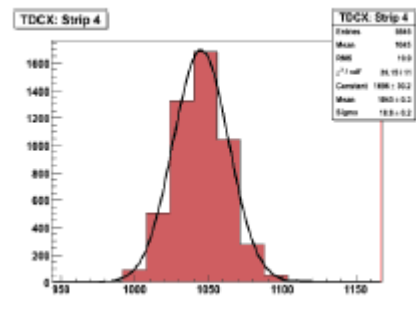

**RPC timing resolution**

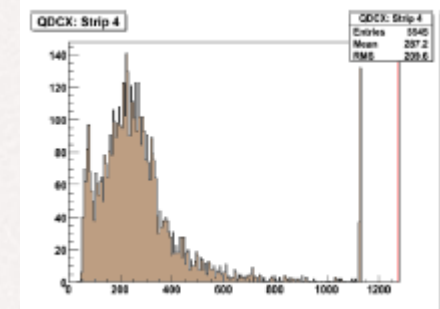

**RPC Pulse ht. resolution**



# Cosmic ray tracks in the RPC stand

- Demonstrates tracking capability of the INO RPC system

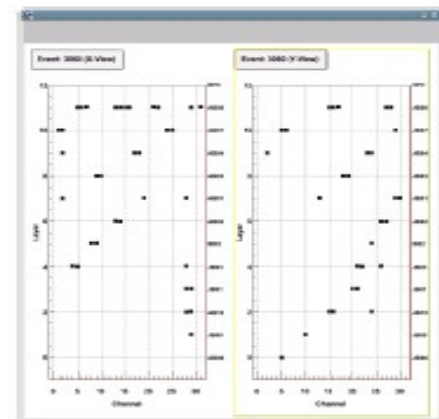
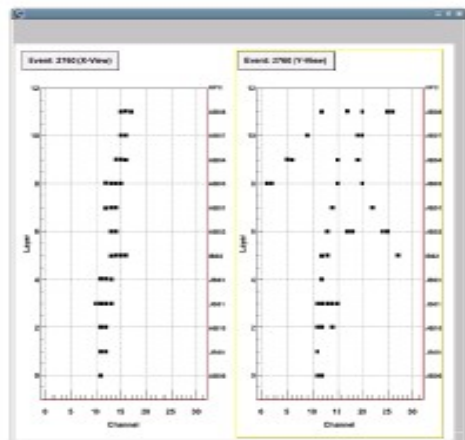
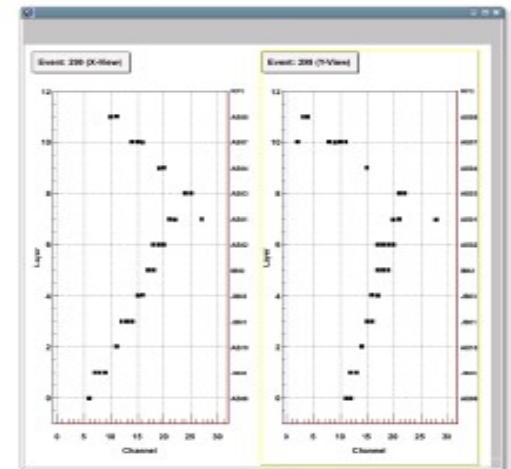
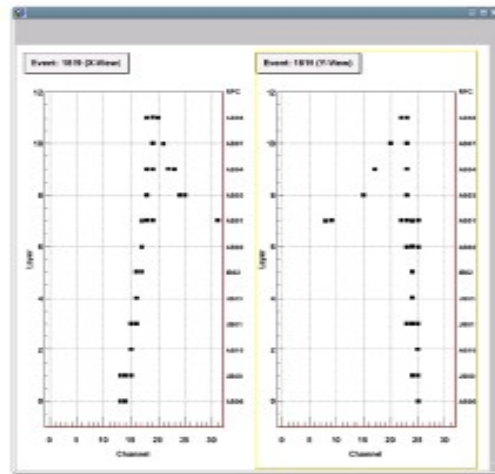
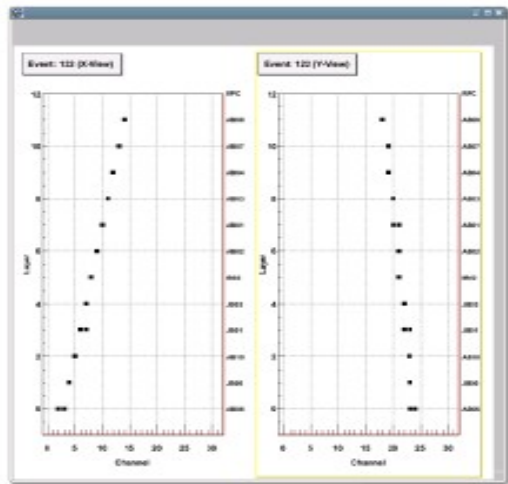

# *RPC performance with cosmic rays*

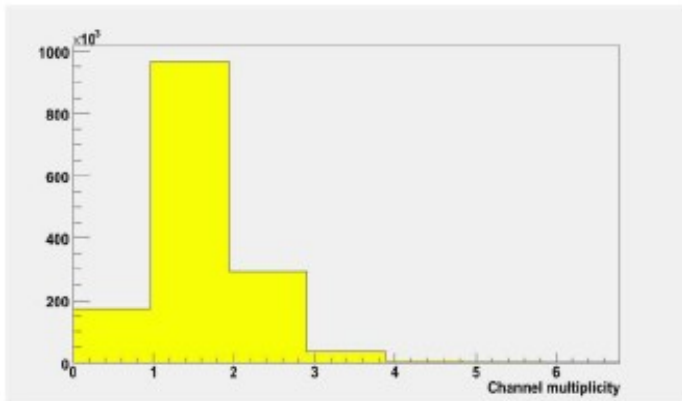

Strip Multiplicity due to crossing muons

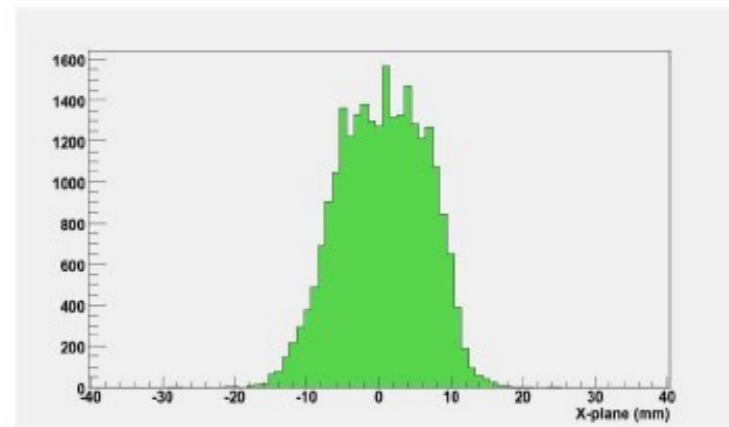

Track residue in mm

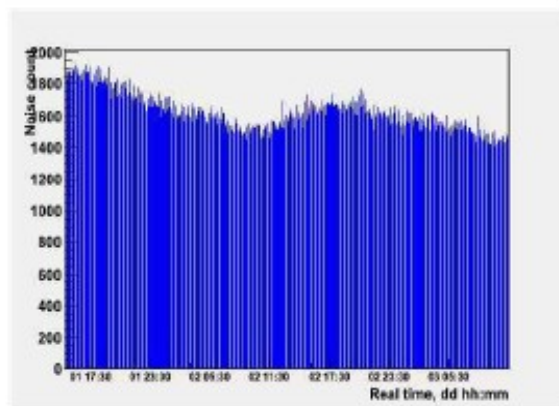

Strip noise rate vs time

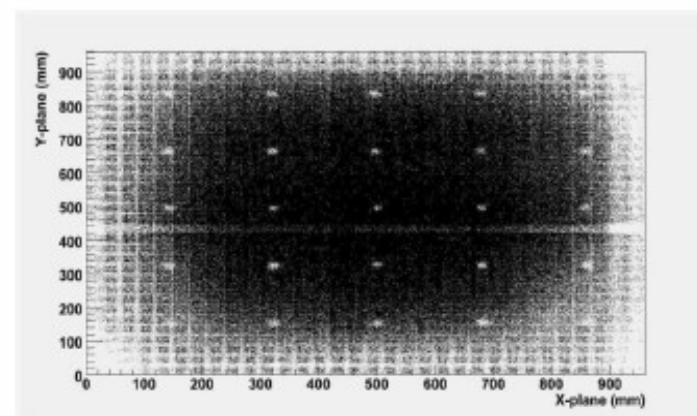

Image of a RPC using muons